

Groke Door Installation Instructions

1. Unpack the crate and carefully take protective plastic cover off door. Do not leave the door exposed to direct sunlight with the plastic wrapping still on the door.
2. Before taking the door out of the crate and setting it upright, place some blankets or thick clumps of the protective plastic wrapping where you plan to set the door on the floor or ground (to protect the lower corners of the door frame).
3. The keys are attached to the outside of the frame.
4. Your door ships with the multi-point locking engaged in the “Locked” position. Unlock the door and open the door, placing some protection under the open corner of the door panel. Note: Do not leave the door unattended while in this open position.
5. For all doors with the integrated keypad, fingerprint scanner, or electronic locks to be operated by an external control, you will need to disconnect the wire channel on the hinge side of the door before lifting the door off its hinges. Lift door off frame and store in a secure location, protecting the bottom of the door.

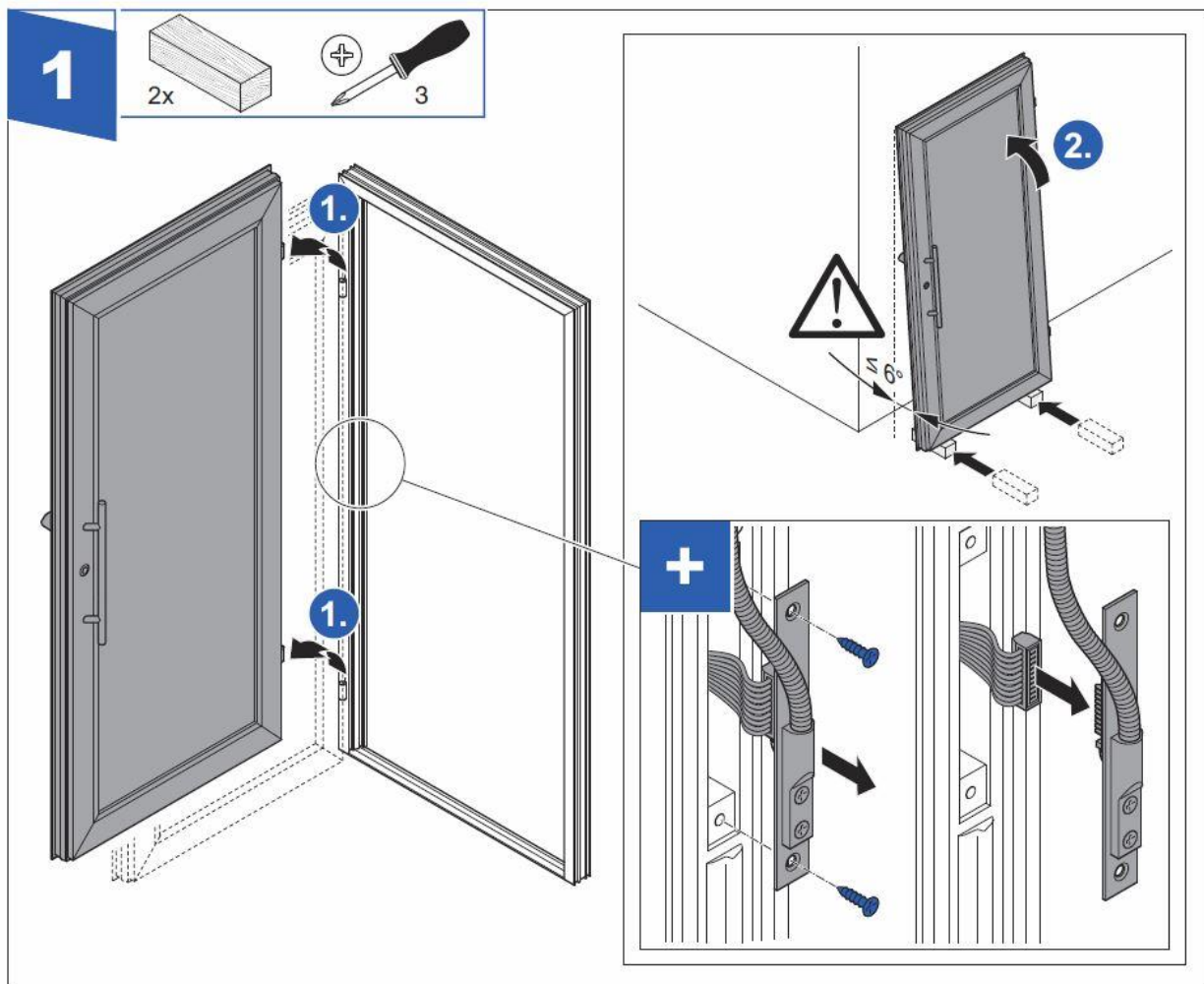

6. Place frame in opening and level

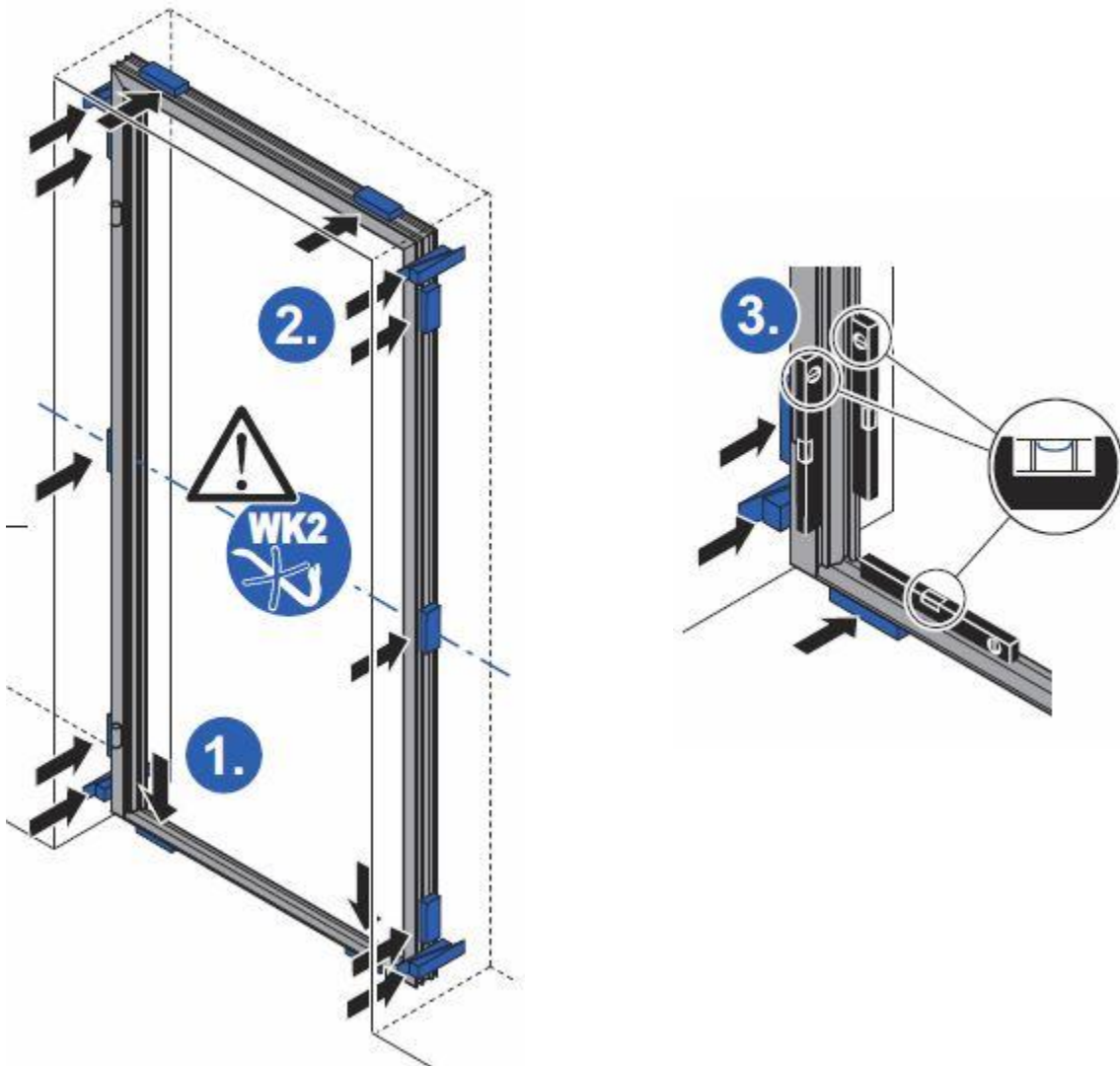

Note: Inswing doors require 5/16" clearance for door to swing clearly.

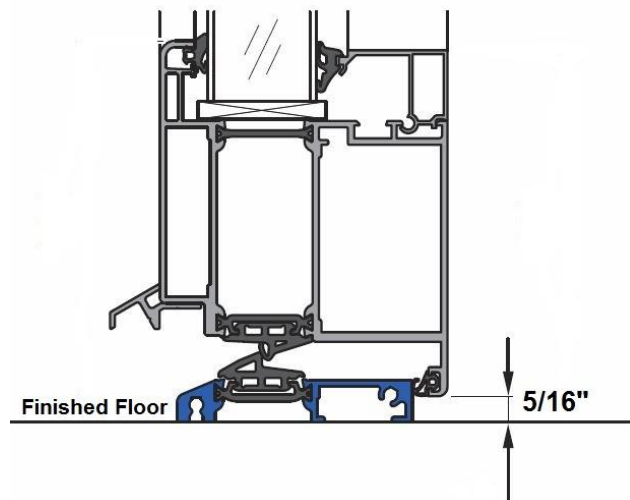

7. Remove gasket to access the mounting groove.
Mount frame to the structure using appropriate fastener.

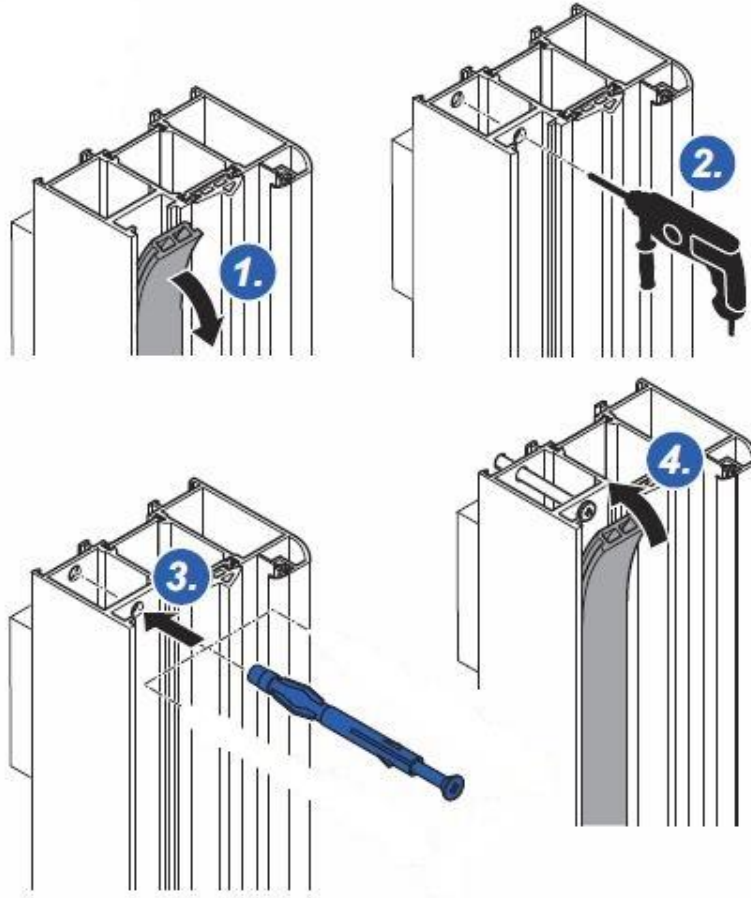

Mounting positions for fasteners

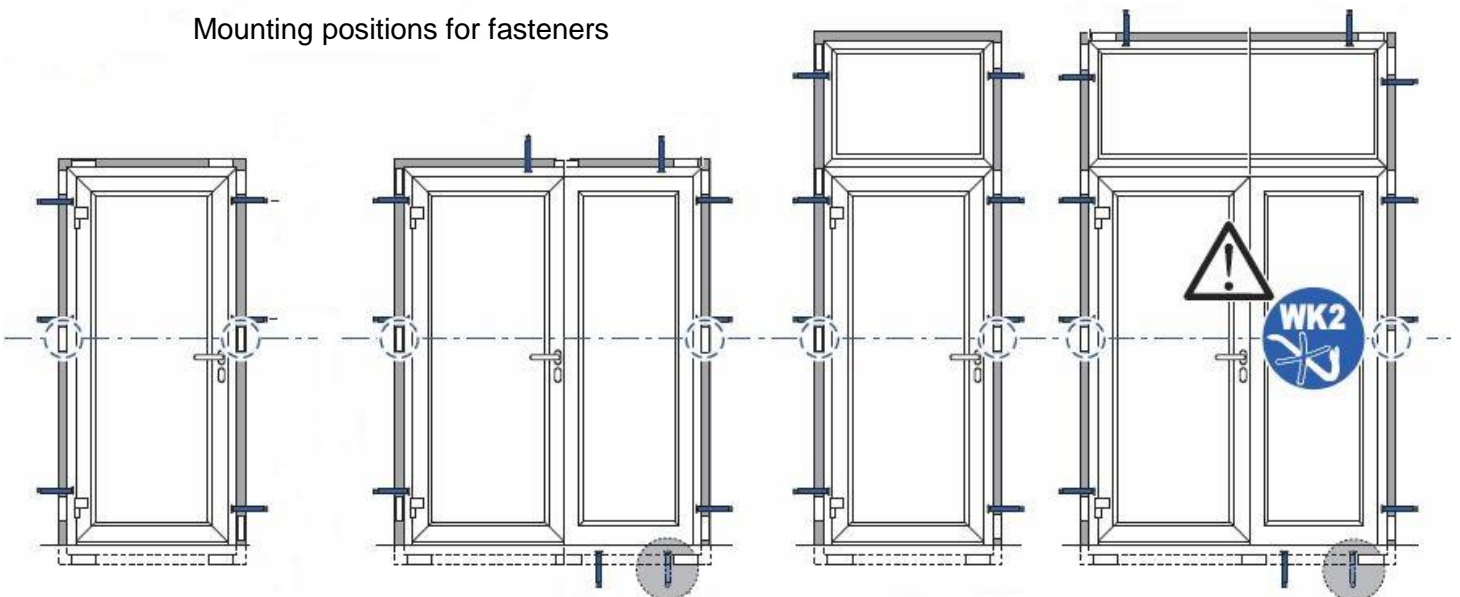

8. Sidelite and Transom installation

Remove gasket and aluminum clip to be able to access the mounting groove.

Note can come out with clips removed. After sidelite or transom is fastened reinstall clips and gaskets

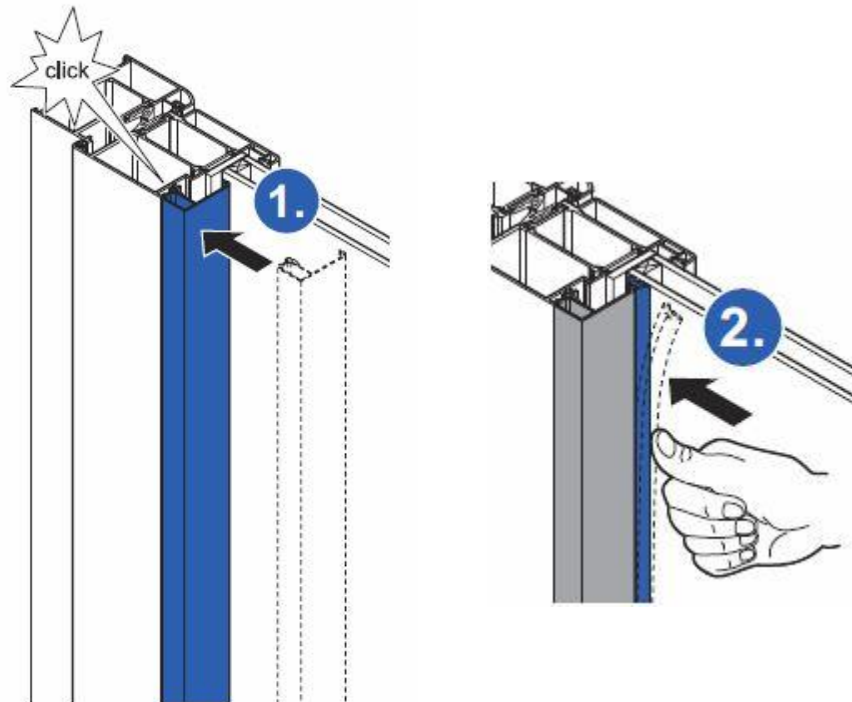

9. Reset door in frame and test operation.

Hinge Adjustment (if necessary)

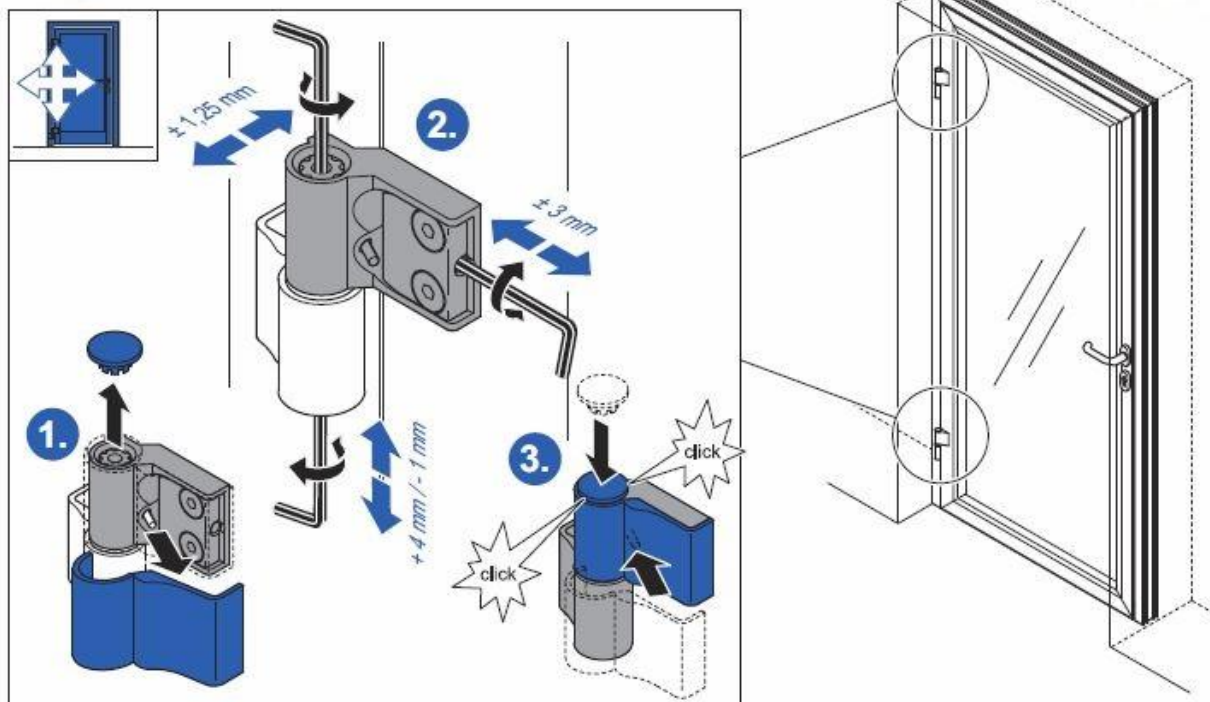

Strike Plate adjustment (if necessary)

